

Model	JS3-3520	JS3-4520	JS3-5520	
<b>Number of Control Axes</b>	4 Axes			
<b>Drive Method</b>	AC Servomotor			
<b>Position Detection Method</b>	Absolute Encoder			
<b>Arm Length</b>	<b>Maximum (J1+J2)</b>	350mm	450mm	550mm
	<b>J1 Arm</b>	125mm	225mm	325mm
	<b>J2 Arm</b>		225mm	
<b>Operation Range</b>	<b>J1 Axis</b>	340°(±170°)		
	<b>J2 Axis</b>	290°(±145°)		
	<b>J3 Axis</b>	200mm		
	<b>J4 Axis</b>	720°(±360°)		
<b>Portable Mass</b>	Maximum 6 kg (Rating 3kg)			
<b>Acceptable Moment of Inertia</b>	Maximum 0.12kgm <sup>2</sup> (Rating 0.01kgm <sup>2</sup> )			
<b>Maximum Speed</b>	<b>J1+J2+J4 Axes Combined</b> <sup>*1</sup>	6900mm/sec	7600mm/sec	8300mm/sec
	<b>J3 Axis</b>		2080mm/sec	
	<b>J4 Axis</b>		2500°/sec	
<b>Standard Cycle Time</b> <sup>*2</sup>		0.29sec		
<b>Repeatability</b> <sup>*3</sup>	<b>J1+J2 Axes Combined</b>	±0.010mm	±0.010mm	±0.012mm
	<b>J3 Axis</b>		±0.010mm	
	<b>J4 Axis</b>		±0.004°	
<b>J3 Axis Resistance</b> <sup>*4</sup>		165N		
<b>Robot Mass</b>	36kg	36kg	37kg	
<b>Tool Wiring</b>	· I/O-H 8 Hand Inputs/8 Hand Outputs · LAN Cable <100BASE-TX>			
<b>Air Piping</b>	Primary: Ø6×2 Tubes, Secondary: Ø4×8 Tubes <sup>*5</sup>			
<b>Control Method</b>	PTP (Point to Point), CP (Continuous Path)			
<b>Interpolation</b>	3-dimensional linear and arc interpolation			
<b>Teaching Method</b>	Remote Teaching (JOG), Manual Data Input (MDI)			
<b>Teaching Pattern</b>	· Direct teaching using optional Teaching Pendant · Offline teaching using optional JR C-Points II PC Software · CAD Data (DXF, Gerber, jpeg) compatible			
<b>Program Capacity</b>	Maximum 999 Programs			
<b>Database Capacity</b> <sup>*6</sup>	Maximum 32,000 Points			
<b>Simple PLC Function</b>	Maximum 1000 Steps			
<b>Screen Display Languages</b>	<b>PC Software</b>	English, Japanese, German, Chinese (both Simplified & Traditional)		
	<b>Teaching Pendant</b>	English, Japanese, German, Italian, Spanish, French, Korean, Chinese (both Simplified & Traditional), Czech, Vietnamese		
<b>External Input/Output</b>	<b>LAN</b>	For robot control via control commands and connection to JR C-Points II PC Software		
	<b>MEMORY</b>	USB Memory Connector (for saving and reading out teaching & customizing data, and for upgrading system software)		
	<b>I/O-SYS</b> <sup>*7</sup>	15 Inputs/14 Outputs		
	<b>I/O-1</b> <sup>*7</sup>	18 Inputs/22 Outputs (including 4 relay outputs)		
	<b>I/O-S</b>	for safety device connection		
	<b>I/O-H</b> <sup>*7</sup>	8 Hand Inputs/8 Hand Outputs		
	<b>COM1, COM2</b>	RS-232C (External Device Control & COM Commands)		
	<b>I/O-MT</b> <sup>*7</sup> (Optional)	Motor Control, Auxiliary Axes 2 Channels		
	<b>Field Networks (Optional)</b>	EtherNet/IP, PROFINET, CC-Link, DeviceNet, PROFIBUS, CANopen		
	<b>Other</b>	Teaching Pendant Connector		
<b>Power Supply</b>	AC200~240V (single phase) ±10% (50/60Hz)			
<b>Power Consumption</b>	1600W			
<b>Operating Environment</b>	<b>Environment Temperature</b>	0~40°C		
	<b>Relative Humidity</b>	45~85% (no condensation)		
	<b>Elevation</b>	Not exceeding 1000m above sea level		

\*1: This is the J1, J2 and J4 axes' maximum speed with a control point on a flat X-Y surface. (The control point is a position 30mm from the center of the J4 axis' rotation.)  
 \*2: Value when bearing a 2kg load. Cycle time may increase when precision workpiece positioning is necessary or due to the robot's operating position(s).  
 \*3: Repeatability is not a guarantee of absolute precision.  
 \*4: The downwards pressing force at the tip of the load when the robot is bearing its maximum load and the J1, J2 and J4 axes are at rest. An excess load error may occur if a pressing force is applied for an extended period of time.  
 \*5: The Ø4 secondary piping is used when the optional solenoid valve is added.  
 \*6: The point data memory capacity may reduce as additional function data settings/point job data/sequencer data are added, due to the shared storage area.  
 \*7: Please choose either NPN or PNP polarity.

<Standard Accessories>  
 · Operation Manual (CD-ROM) · Short Connectors for (Teaching Pendant, I/O-S and I/O-SYS) · Robot to Controller Connector Cable

<Options>  
 · Teaching Pendant · Operation Box · Controller Power Cord · I/O-1 Cable & Connector · I/O-MT Cable & Connector  
 · Solenoid Valve (NPN/PNP) · Hand Output Cable · Hand Input Cable · Curled Tube for Hand Cables · Built-in Hand Wiring & Tubing  
 · External Wiring & Tubing Box · Mechanical Stopper for J1 Range Modification · J1/J2 Adjustment Tool · PC Software JR C-Points II (Windows®7/8.1/10 compatible)

• Before using the robot, please read the operation manual and make sure you are using the robot correctly.  
 • Specifications may change without notice to improve product quality.  
 • If you have any questions, please contact us at the telephone number listed below, or visit our website.

C33-00(04.1)EN 2022.3-000

SCARA ROBOT  
**JS3 SERIES**

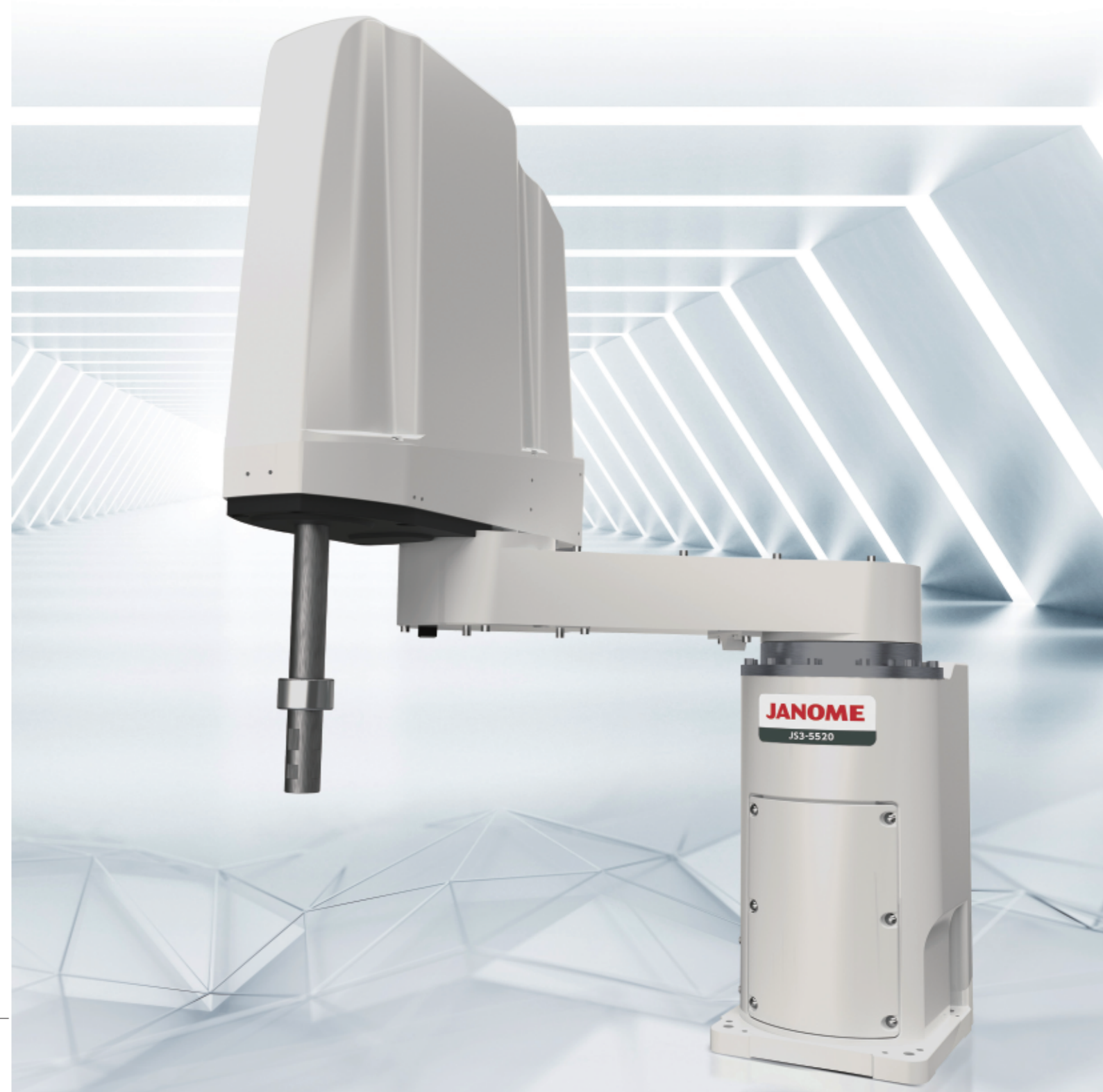

**JANOME Corporation**  
**Industrial Equipment Sales Division**

1463 Hazama-machi, Hachioji-shi, Tokyo 193-0941, Japan  
 Tel: +81-42-661-6301 FAX: +81-42-661-6302  
 E-mail : j-industry@gm.janome.co.jp  
 URL: www.janome.co.jp/industrial.html

# Cut costs with our user-friendly, fast and highly functional SCARA Robot!

Highly rigid SCARA robot arm offers high speed, high precision and heavy payload capabilities! Using our own easy-to-use teaching software, make fine adjustments while the robot runs. Setup is simple, and the JS3 is useful for a wide range of jobs, from high-speed small parts pick-and-place transport to high-precision assembly.

## User Friendly Teaching

Teach using our interactive teaching pendant or get a hands-on feel for the robot's operation teaching via our PC software. Shorten your equipment setup time and easily make fine adjustments while running the robot.

Standard Pick & Place Dispensing\*

**Teaching Pendant**

**PC Software**

**Basic Operation Area**  
Easy Teaching : just click the icons.  
**Pick & Place Model**  
All the standard operations you need and helpful Pick & Place icons to save time when teaching.

**Robot Operation Area**

\*For details about the Dispensing Model, please contact us.



## Cable Interference Prevention

Axis tip available with interior hand wiring and piping for compact, streamlined hand installation.

## Works Fast!

Our standard cycle time is top class: 0.29sec, with a maximum speed of 8,300mm/sec, helpful for shorter tact times and greater efficiency.

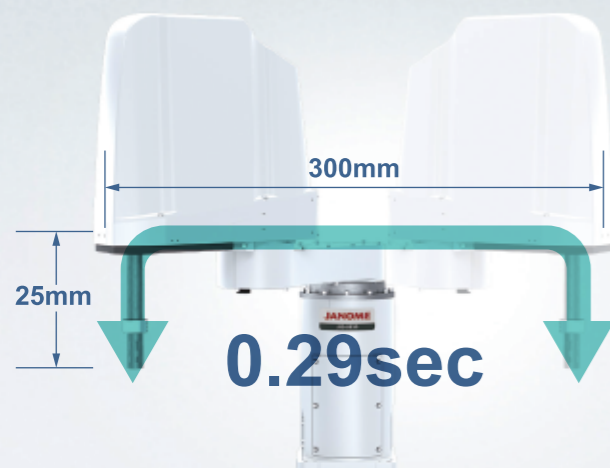

## Abundant Communication Functions

Our dedicated controller has a LAN port as standard equipment, and is compatible with 6 field networks.

- EtherNet/IP
- PROFINET
- CC-Link
- DeviceNet
- PROFIBUS
- CANopen



## Built-in Simple PLC Function

The robot comes with its own simple PLC function for basic communication with external devices; no need for a separate PLC.

```

PLC Program 1 1/3
001 id #genIn0
002 and #genIn5
003 out #genOut1
004 mps
005 id #mv(1)
006 or #mv(2)
007 and #genIn2
008 out #genOut2
009 out #mv(3)
010 mrd
011 and #mv(3)
012 set #genOut3
    
```

## Model

# JS3 - 35 20

Maximum Arm Length	J3 Axis Operating Range
35: 350mm	20: 200mm
45: 450mm	
55: 550mm	



## Operating Ranges

### JS3-3520

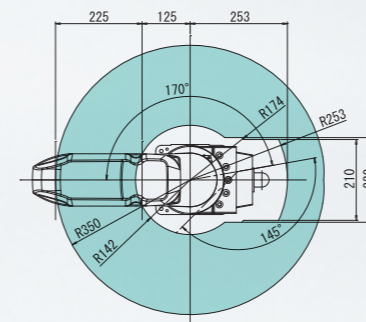

### JS3-4520

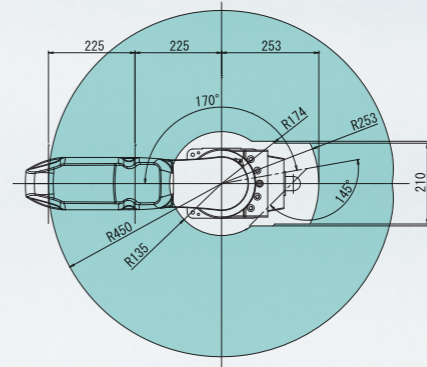

### JS3-5520

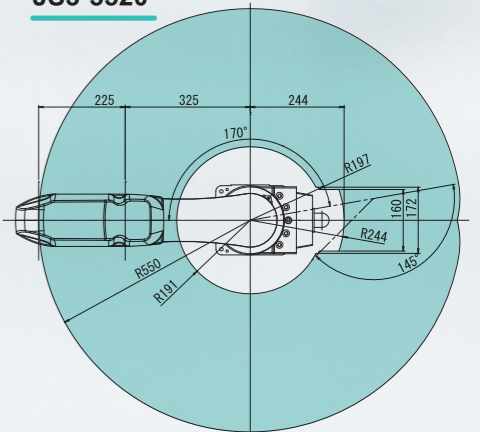

## External Dimensions

### Robot Unit

#### JS3-3520

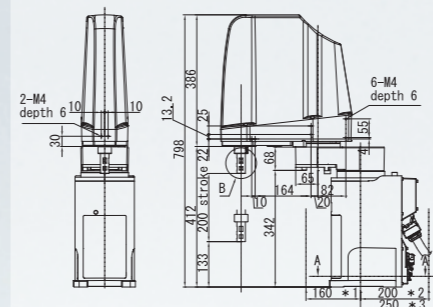

#### JS3-4520

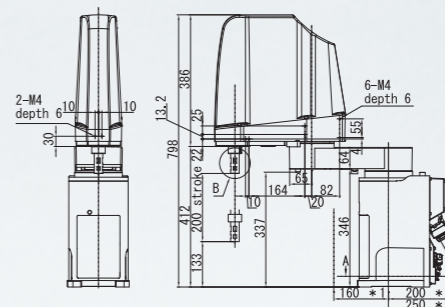

#### JS3-5520

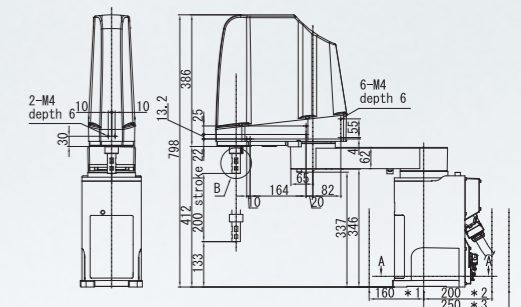

\*1: Necessary clearance for battery replacement. \*2: Necessary distance for the controller cable minimum bend radius. \*3: Necessary clearance for controller cable connection.

### Robot Unit (Common to All Sizes)

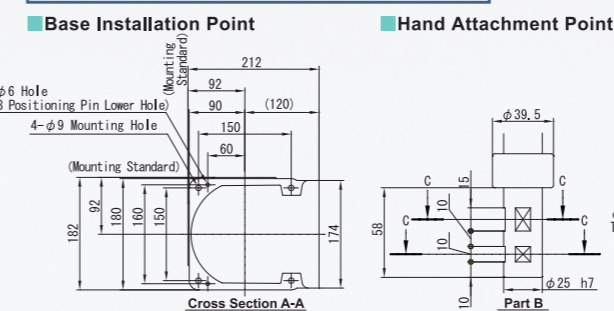

### Controller (Common to All Sizes)

